

Y-BCV SERİSİ

POMPA KONTROL VANASI

PUMP CONTROL VALVES



ÜRÜN TANIMI-PRODUCT DESCRIPTION

Pompaj sistemlerinde, pompaların basma hattına monte edilen pompa kontrol vanaları pompalar ile senkronize olarak çalışırlar. Vana ile pompa arasındaki senkronizasyon bir pompa kontrol panosu sayesinde gerçekleştirir. Pompa kontrol panosu pompayı ve vanayı birlikte kontrol eder.

The pumping control valves mounted in the pumping lines of pumping systems work synchronized with the pumps. The synchronization with the pump and the valve is done with a pump control panel. The pump control panel controls the pump and the valve together.

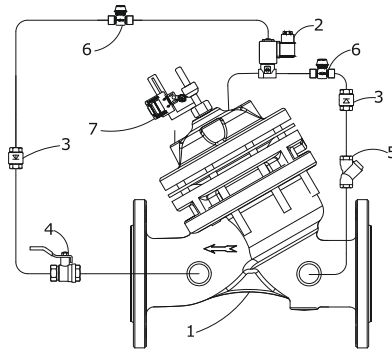

1. Hidrolik Kontrol Vanası / Main Valve
2. Solenoid Valf / Solenoid Valve
3. Çekvalf / Checkvalve
4. Küresel Vana / Ball Valve
5. Pislik Tutucu / Strainer
6. İğne Valf / Needle Valve
7. Limit Switch Asamblesi

ÖRNEK MONTAJ-INSTALLATION EXAMPLE

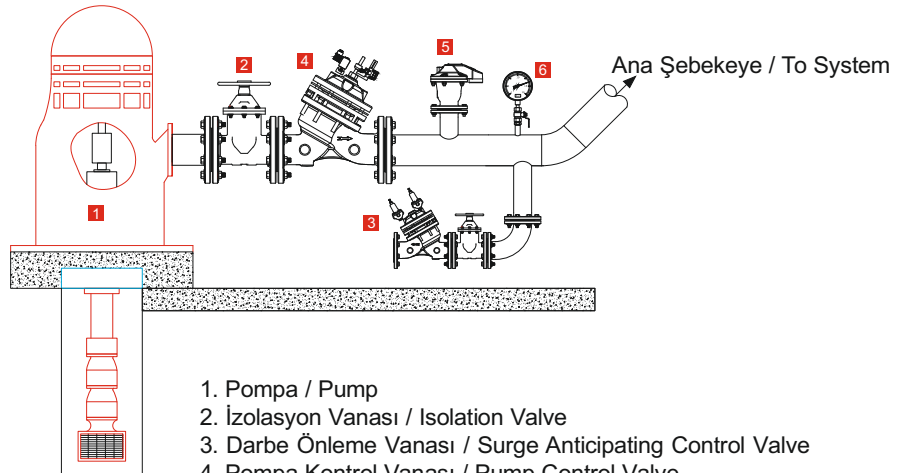

1. Pompa / Pump
2. İzolasyon Vanası / Isolation Valve
3. Darbe Önleme Vanası / Surge Anticipating Control Valve
4. Pompa Kontrol Vanası / Pump Control Valve
5. Hava Tahliye Vanası / Air Valve
6. Manometre / Pressure Gauge